

IDENTIFICATION OF MACHINES

Each UNION SPECIAL LEWIS machine carries a style number which is stamped into the style plate located on the head of the machine. The serial number of each machine is stamped in the arm under the top cover.

APPLICATION OF CATALOG

This catalog is a supplement to Catalog No. 194-9 and should be used in conjunction therewith. Only those parts which are used on Styles 150-260 and 150-270, but not on Style 150-230 are illustrated and listed at the back of this book. The parts are identified by a reference number and this reference number is then used to obtain the part number, description and amount required. Any part that is a component of another part is illustrated on the picture plate by having the reference number or numbers inside a bracket or box. On the copy page a component part is indicated by indenting its description under the description of the assembly or base part. Always use the part number in the second column, never use the reference number in the first column when ordering repair parts.

The catalog applies specifically to the Standard Style of machine as listed herein. It can also be applied with discretion to other Styles of machines in this class. References to direction, such as right, left, front, back, etc., are given from the operator's position while seated at the machine.

DESCRIPTION OF MACHINES

Single Thread, Single Curved Needle, Non-Skip Stitch, Chainstitch, Blind Stitch Machine, Needle Travels from Left to Right and Penetrates at an Angle 90° to Line-of-Feed. Calibrated Penetration Adjustment, Push Button for Quick Easy Adjustment of the Stitch Length. Knee Lifter for Inserting and Removing Work. Independent Ridge Forming Discs Which Permits the Needle to Penetrate Alternate Sides of the Seam on Each Stitch. Equipped with Stationary Work Support Plate.

150-260 For hemming bottoms on medium weight fabrics (skirts, coats, etc.), tacking facings to the foreparts (fronts) on women's medium weight coats and similar operations on medium weight fabrics. Seam specification 105-EF1-1 (Modified).

150-270 For hemming bottoms on light weight fabrics (dresses, skirts), with raw pinked, serged or piped edges and similar operations on light weight fabrics. Seam specification 105-EF1-1 (Modified).

OILING

The machine should be oiled twice daily, before the morning and afternoon starts. Use a good grade of straight mineral oil with a Saybolt viscosity of 90 to 125 seconds at 100° Fahrenheit. Oiling places on the machine are painted red. However, reference to the oiling diagram (Fig. 1) will be beneficial.

SPEED

Maximum recommended speed for these machines is 3000 R. P. M. The operating direction of handwheel is away from the operator.

STARTING TO OPERATE (Continued)

5. The edge guide (S, Fig. 2) has only a lateral adjustment and should be set so that the folded edge of the material is guided directly over the right hand ridge forming disc. Looper guard (T) should be set so as not to contact the cloth retainer while sewing over maximum thickness of material, yet low enough to assure that cloth retainer cannot flip up into the path of the looper. In operating the machine, hold the folded edge of the material against the edge guide.
6. Removing work. To remove work after stitching, see that the needle is entirely withdrawn from the material, push the knee press to the right and remove the work with a quick pull away from you, in order to break the thread and lock the stitch.

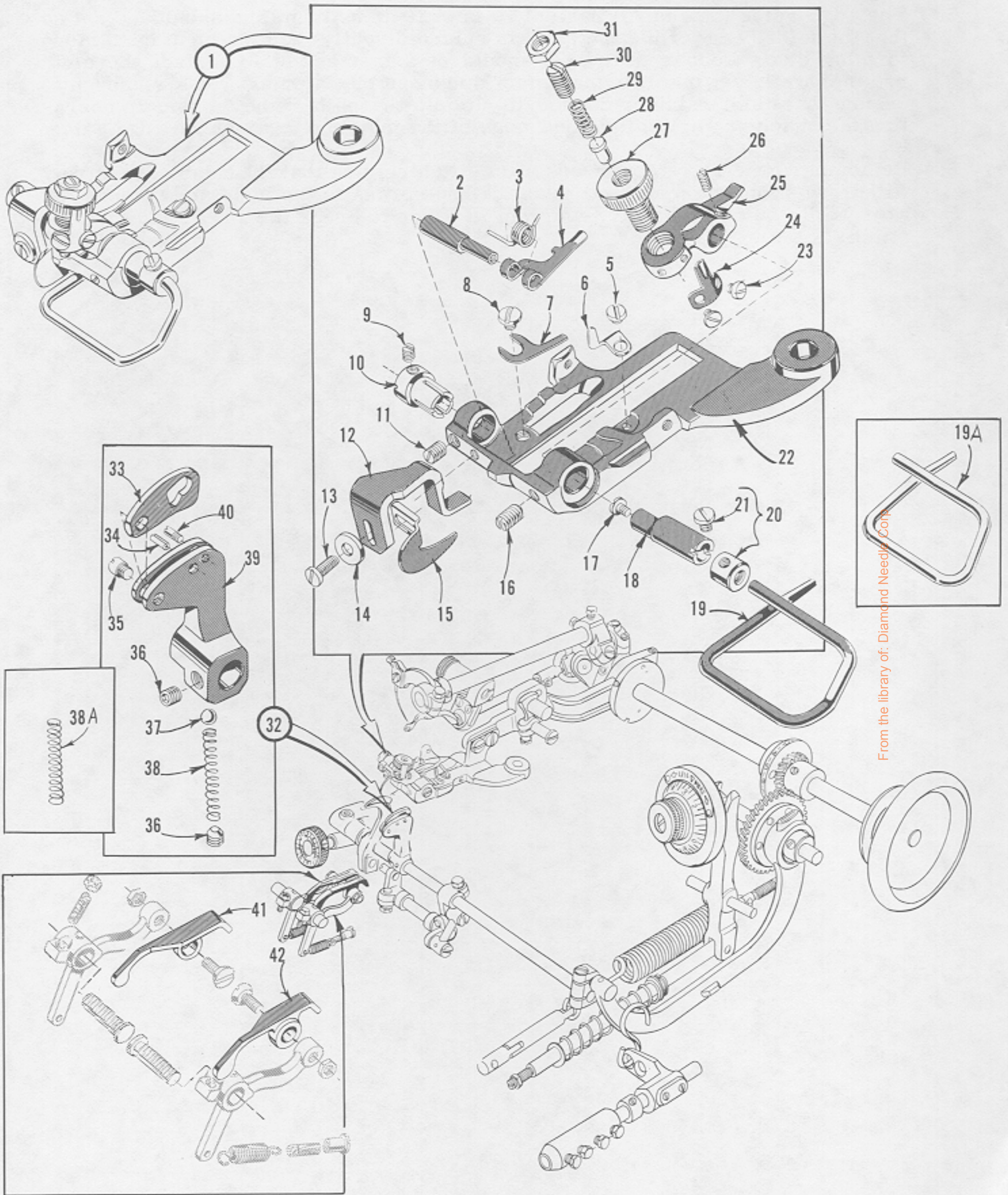

From the library of: Diamond Needle Corp.

The parts illustrated on page 14 and described on this page, represent the parts that are used on Styles 150-260 and 150-270, but not used on Style 150-230, improved machines.

Those parts shown in phantom views and bearing no reference numbers are common to Styles 150-230, 150-260 and 150-270.

Use Catalog No. 194-9 for all parts not illustrated or described here.

Reference numbers that are inside a bracket or box on the picture plate and have indented descriptions, indicate they are components of a complete part or assembly.

PRESSER FOOT, RIDGE FORMING DISC AND FEED PLATES

<u>Ref. No.</u>	<u>Part No.</u>	<u>Description</u>	<u>Amt. Req.</u>
1	405-587	Presser Foot Assembly, for Style 150-260 -----	1
-	405-588	Presser Foot Assembly, for Style 150-270 -----	1
2	17-87	Eccentric Stud -----	1
3	21-240	Spring-----	1
4	137-77	Retainer -----	1
5	18-292	Screw -----	1
6	122-C38	Chaining Finger -----	1
7	6-56	Needle Guide -----	1
8	18-643	Screw -----	1
9	18-416	Set Screw -----	1
10	16-214	Bushing, spring tensioning -----	1
11	1081 L	Screw -----	1
12	8-141	Disc Guard, marked "A" -----	1
13	18-989	Screw -----	1
14	41358	Washer -----	1
15	75-251	Edge Guide -----	1
16	LS330	Set Screw -----	1
17	73 A	Screw -----	1
18	17-180	Eccentric Stud -----	1
19	44-332	Cloth Guide, for No. 405-587 -----	1
19A	44-331	Cloth Guide, for No. 405-588 -----	1
20	39-149	Collar -----	1
21	73 A	Screw -----	1
22	5-587	Presser Foot, main section, for No. 405-587 -----	1
-	5-588	Presser Foot, main section, for No. 405-588 -----	1
23	18-261	Screw -----	2
24	1733 L	Spring, retaining -----	1
25	126-59	Crown-----	1
26	79077	Screw -----	1
27	18-1109	Knurled Adjusting Screw -----	1
28	22-317	Pin -----	1
29	21-300	Spring-----	1
30	22560 A	Screw, spring tension adjusting -----	1
31	12934 A	Nut, locking -----	1
32	444-330-1	Yielding Ridge Former Assembly, for Style 150-260 -----	1
-	444-330	Yielding Ridge Former Assembly, for Style 150-270 -----	1
33	44-330	Ridge Forming Disc, marked "A" -----	1
34	96653	Pin -----	1
35	22845 A	Screw -----	1
36	22894 P	Set Screw-----	2
37	999-143	Ball-----	1
38	21-433	Spring, for No. 444-330 -----	1
38A	21-445	Spring, for No. 444-330-1-----	1
39	99-355	Ridge Former Holder -----	1
40	22799 U	Screw -----	1
41	24-331	Feed Plate, left -----	1
42	24-332	Feed Plate, right-----	1

From the library of: Diamond Needle Corp

NEEDLES

Use only genuine UNION SPECIAL needles. The needles are packaged under our brand name *Union Special*®. The recommended needle for Style 150-260 is Type 29 BL-100/040. It has a blade diameter of .040 inch (1.00 mm). The recommended needle for Style 150-270 is Type 29 BL-075/029. It has a blade diameter of .029 inch (.75 mm). They are also available in the following sizes:

Needle Type	Size	
	Inches	Millimeters
29 BL-065/025	.025	.65
29 BL-075/029	.029	.75
29 BL-090/036	.036	.90
29 BL-100/040	.040	1.00
29 BL-110/044	.044	1.10
29 BM-075/029	.029 (ball point)	.75
29 BM-090/036	.036 (ball point)	.90

Selection of proper needle size is determined by size of thread and weight of material used. Thread should pass freely through needle eye in order to produce a good stitch formation.

To have needle orders promptly and accurately filled, an empty package, a sample needle, or the Type number should be forwarded. Use the description on the label. A complete order would read: '100 Needles, Type 29 BL-100/040.

CHANGING NEEDLES

When changing the needle, make sure that it is inserted in the needle carrier as far as it will go and tighten clamp screw securely.

Immediately discard any needle which may have a hooked or blunt point, as improper needle penetration will result.

THREADING

To thread the machine, turn handwheel in operating direction until the needle carrier is in its highest position. Refer to threading diagram (Fig. 1).

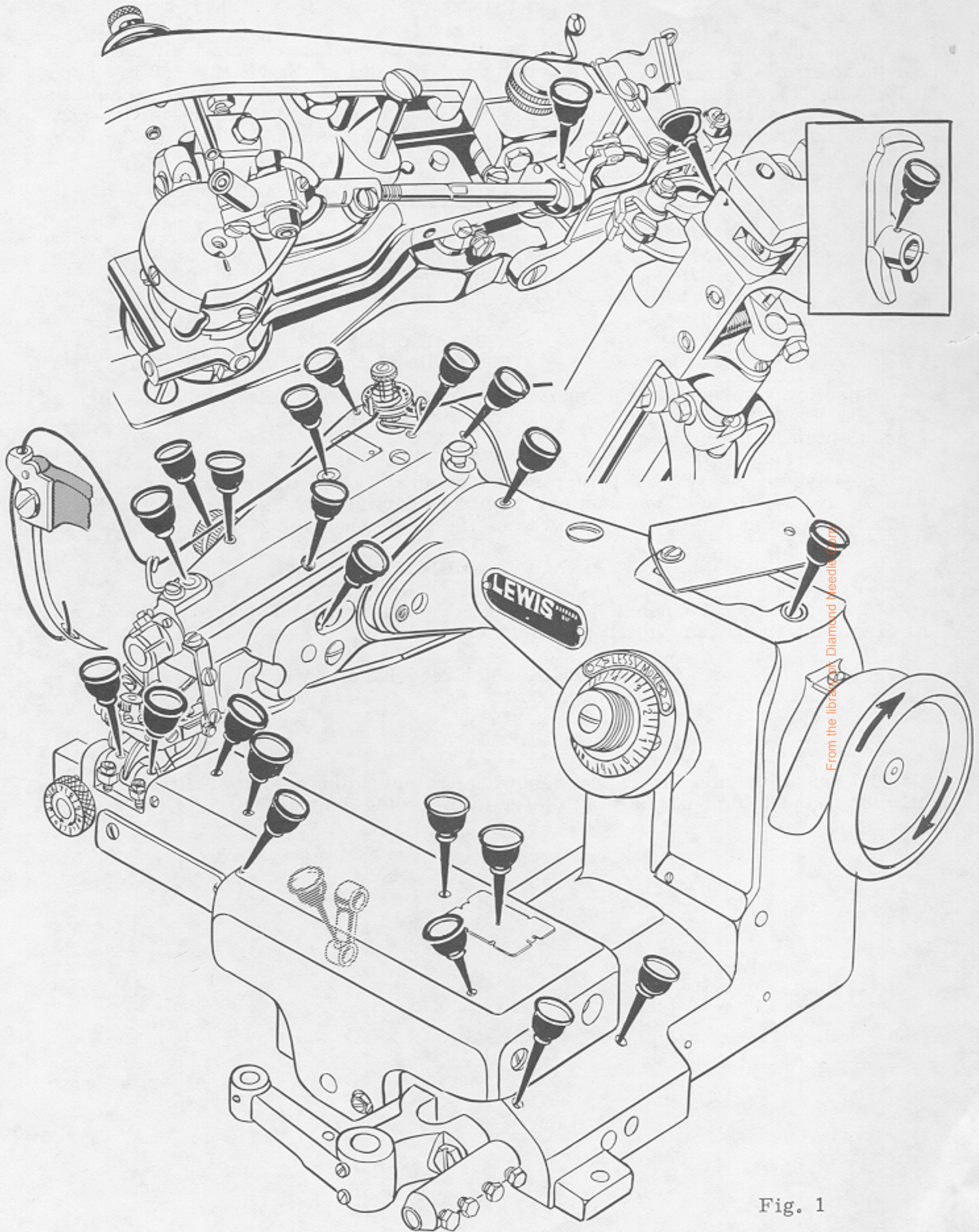

From the library of Diamond Needle Corp.

Fig. 1

ADJUSTING

ADJUSTING PRESSER FOOT TO NEEDLE

A view of the presser foot (Fig. 2) is shown to illustrate the various parts of the foot which are referred to in this and subsequent adjustments.

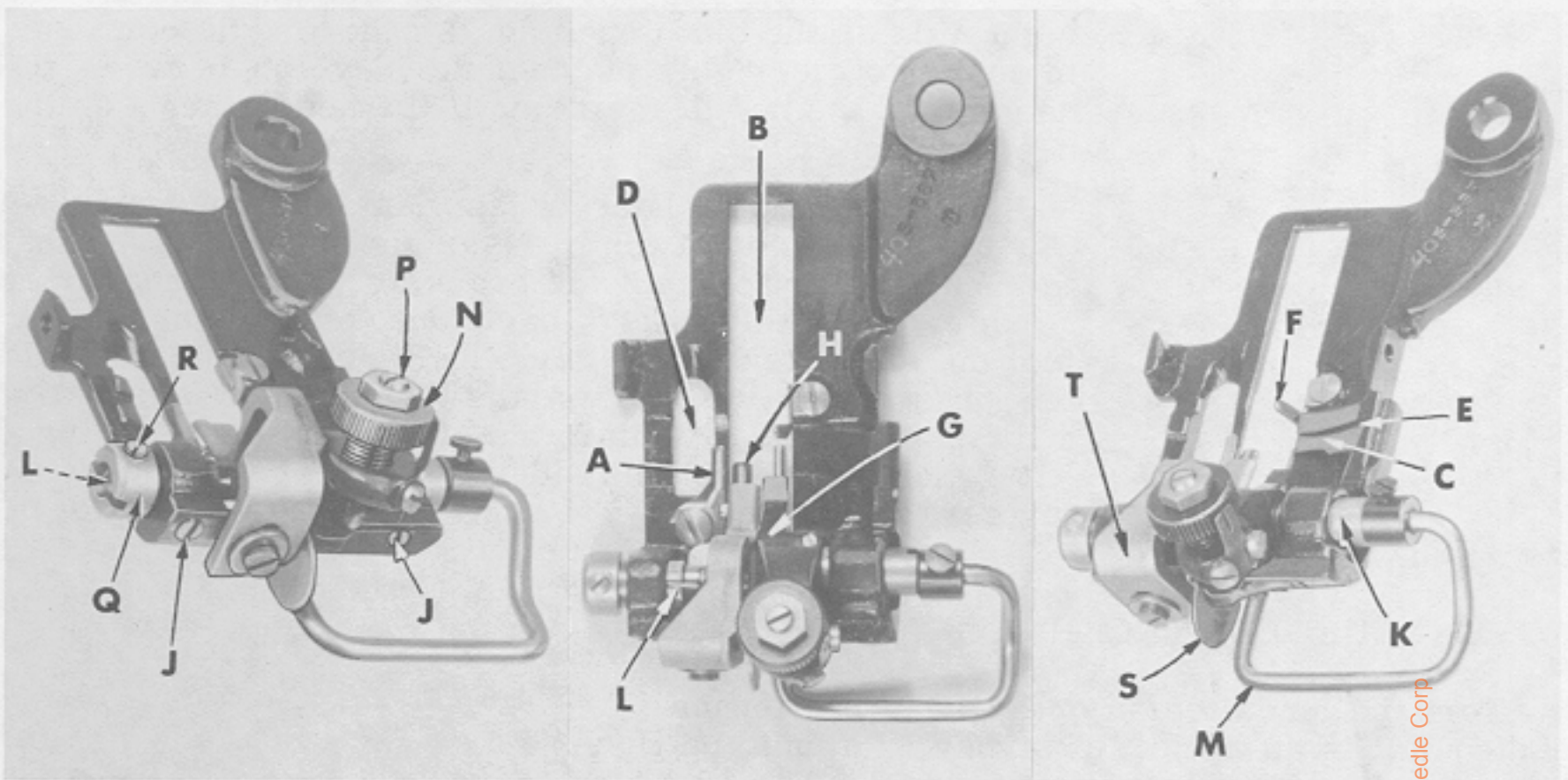

Fig. 2

Below is the key to the labeling as shown in Fig. 2.

- A - Needle guide
- B - Cloth opening
- C - Needle track
- D - Looper opening
- E - Radius run-out edge
- F - Chaining finger
- G - Crown
- H - Cloth retainer
- J - Eccentric stud set screws
- K - Eccentric stud
- L - Eccentric stud
- M - Cloth guide
- N - Knurled adjusting screw (for right cloth retainer)
- P - Set screw
- Q - Spring adjusting sleeve (for left cloth retainer)
- R - Set screw
- S - Edge guide
- T - Looper guard

From the library of: Diamond Needle Corp

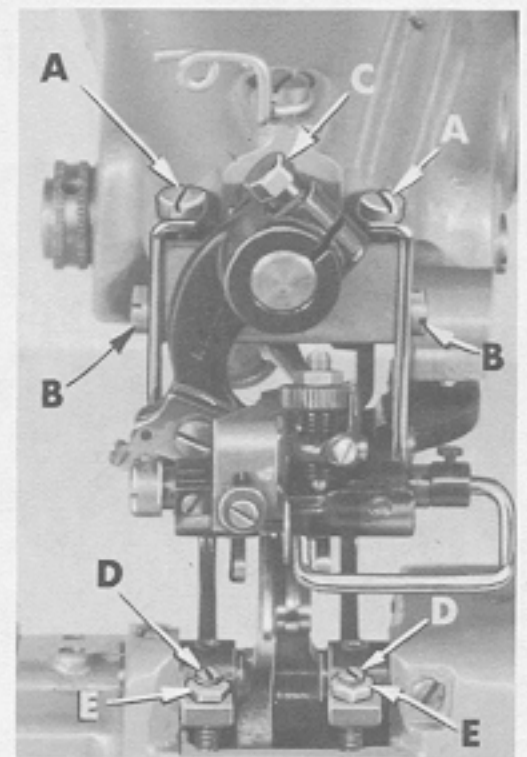

Fig. 3

ADJUSTING PRESSER FOOT TO NEEDLE (Continued)

Insert a new needle of proper type and size, as far as it will go into the needle carrier and securely tighten the clamp screw. Set the presser foot to the needle so the needle point contacts the needle guide (A, Fig. 2) when traveling from left to right and so that the needle remains in contact with the needle guide until the point of the needle lies in the span between the center of the cloth opening (B) and the right side of the cloth opening. As the needle continues to move to the right, play should develop between the needle and the needle guide until the needle reaches the needle track (C).

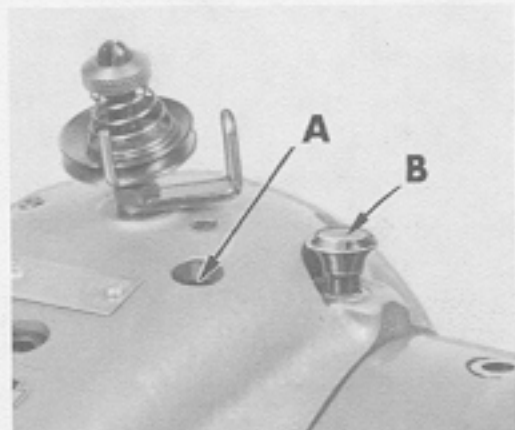

Fig. 4

attempted.

SETTING NEEDLE STROKE

Turn the handwheel in operating direction until the needle point is at the left of stroke. It should be flush with the left side of looper opening (D, Fig. 2). The needle point, at right of stroke, should be to the top of radius run-out edge (E). If this is not the case, the travel of the needle will have to be adjusted in the following manner.

Turn the handwheel in operating direction until the needle eye is flush with the right side of the cloth opening (B, Fig. 2) in the presser foot. Loosen the clamp screw in the needle crank (accessible through the hole located at point A, Fig. 4) in top of the head). Turn the handwheel in operating direction until the needle carrier is at its extreme right end of travel. Remove head cover and turn the needle eccentric ball stud (A, Fig. 5) so that its slot is vertical and the punch marks in the ball stud are down, as viewed in Fig. 5. The needle eccentric ball stud is located in the head, at the back near the top. Retighten the clamp screw and recheck the position of the needle point in relation to the left side of the looper opening. Loosen needle carrier clamp screw (C, Fig. 3) and rotate carrier as required for above setting. Also, the needle carrier should be set front to back so the side of the needle is flush to .003 inch (.076 mm) away from vertical wall at the right side of presser foot. It may be necessary to slightly retard or advance the above adjustments to obtain desired results. CAUTION: When adjusting the needle eccentric ball stud, make sure that it is seated against the needle shaft crank.

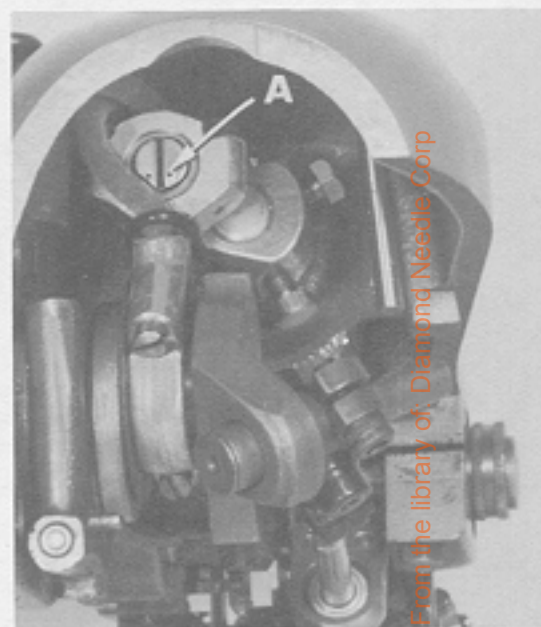

Fig. 5

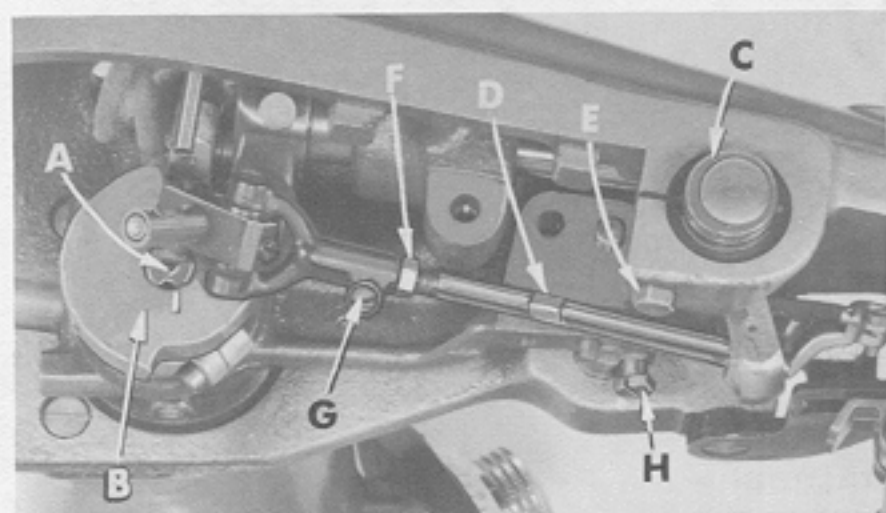

Fig. 6

results. CAUTION: When adjusting the needle eccentric ball stud, make sure that it is seated against the needle shaft crank.

LOOPER TIMING AND ADJUSTMENT

Insert the looper in its holder so that the flat on its shank corresponds with flat on holder and is seated in the holder. In the left end of the mainshaft (A, Fig. 6) is a "V" groove and on the looper crank (B), there is a timing line.

Turn the handwheel in operating direction until the "V" groove in the mainshaft is at bottom. Loosen two screws (A, Fig. 7) in the looper crank (B) and position the crank so that its timing line coincides with the right edge of the "V" groove in the mainshaft (See Fig. 6). This is merely an approximate setting. Again turn the handwheel in operating direction until the point of the long prong of the looper is over the spot in the needle. At this time, the long prong of the looper should be from $3/64$ to $5/64$ inch (1.19 to 1.98 mm) away from the left end of the needle eye. The short prong of the looper should clear the chaining finger (F, Fig. 2) of the presser foot by no more than $1/32$ inch (.79 mm) and cross the needle slightly higher than the long prong. The long prong looper point should be close to the needle spot, but

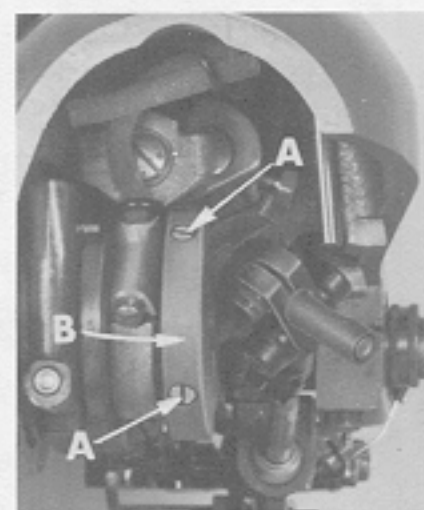

Fig. 7

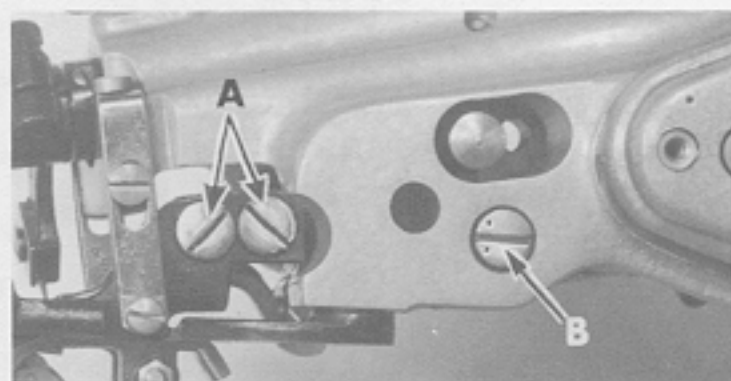

Fig. 8

(E) and moving the adjusting sleeve in or out. Vertical or height adjustment is secured by rotating the sleeve.

The looper holder connecting rod also adjusts the looper vertically, but to a greater extent than the adjusting sleeve. If the looper is radically out of adjustment, to the spot of the needle, initial adjustment can be made by loosening the nut (F, Fig. 6) on the connecting rod (D), clamp screw (G) in connecting rod yoke and turning the connecting rod, rolling the looper to the desired height. Retighten clamp screw and connecting rod lock nut to maintain the desired height. If only a slight amount of height adjustment is required, it can be secured by rotating the looper adjusting sleeve as previously described, though final setting involves a coordinated adjustment of both the connecting rod and adjusting sleeve.

SETTING FEED DOG

As the needle travels from right to left, the feed dog should contact feed plates when point of needle is flush with right side of cloth opening and feed dog is $3/16$ inch (4.76 mm) behind needle. Feed dog should depress feed plates approximately the depth of a full tooth. The feed dog is adjusted by means of two screws (A, Fig. 8) on the right side of the head. The slot in eccentric stud (B) should be horizontal when the feed bar is all the way towards the operator and the punch marks at the end of the slot in the stud should be towards the operator. To position stud, loosen clamp screw (H, Fig. 6) and position stud as required, retighten clamp screw. It may be necessary to rotate the punch marks down in stud to obtain a full tooth depth for shorter number of stitches. CAUTION: Feed dog must not graze looper or the back of the feed dog slot in the presser foot.

SETTING FEED PLATES

Pressure on the feed plates is controlled by two nuts (A, Fig. 9) located in the back of the cylinder. Turning them counterclockwise increases the tension and turning the nuts clockwise acts the reverse. Each feed plate is controlled by separate springs which should be adjusted so that the tensions on the plates will compensate for varying thicknesses of material and cause the work to feed uniformly.

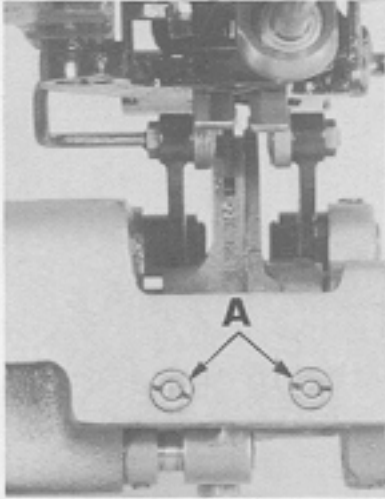

Fig. 9

There must be enough pressure applied to keep the material from moving when the needle makes its penetration. The feed plates should drop uniformly when the cylinder is depressed. Feed plate holder adjusting screws (D, Fig. 3) should be set $1/32$ inch (.79 mm) from work table with the work table in operating position and locked by nuts (E).

CHANGING STITCH LENGTH

The stitch length is regulated by the knob (B, Fig. 4) on the arm of the machine near the head. Open the top cover on the arm and observe the feed indicator on the shaft with numerals which indicate the number of stitches per inch. Press the knob down which will engage in a slot in the feed mechanism. While holding the knob down, turn the handwheel until the number corresponding to the desired amount of stitches per inch appears directly under the indicator. Release knob. The stitch range of the machine is from 3 to 8 stitches per inch.

SETTING RIDGE FORMING DISCS

These machines are equipped with two ridge forming discs. The left ridge forming disc is a "solid" type, while the right ridge forming disc is a "yielding" type.

The "right" ridge forming disc should be set to measure $3/32$ inch (2.38 mm) between right side of cloth opening in presser foot and the right side of ridge forming disc, for Style 150-260. This measurement should be $1/8$ inch (3.17 mm), for Style 150-270. The "left" ridge forming disc should be set as close as possible to the "right" ridge forming disc without contacting, for both Styles.

Two dial knobs control the height adjustment of the ridge forming discs.

The right hand dial knob, located on the arm of the machine, adjusts the position of the work table which, in turn, raises or lowers both ridge forming discs.

The left hand dial knob, located at the left end of the work table, adjusts the height of the left hand ridge forming disc independently of the right, and is used to compensate for differences in the number of plies of material being sewn.

The height of the ridge forming discs is set at the factory so that the right hand disc is sufficiently high that the needle just penetrates the top ply of three plies of material. The left hand disc is set so that the needle just penetrates one ply of material.

An additional adjustment is provided with the right yielding ridge former. Mounted in the presser foot and located over the ridge former is a compensating spring actuated crown (G, Fig. 2). With this device, it is possible to regulate the depth of needle penetration from the top side of the presser foot.

SETTING RIDGE FORMING DISCS (Continued)

The compensating spring in the crown insures continual contact with the fold of material during the full travel of the ridge former. As the ridge former travels to the point of penetration, the crown is set to come to a positive stop in its upward travel. Because of this condition, the needle will always penetrate the same distance from the top of the work. Any variation in thickness of the work, such as when crossing seams, will cause the ridge former to yield.

When making the preliminary penetration setting of the right ridge former, insert folded material comparable to the weight of material to be hemmed and raise the crown so that it does not contact the work. By using the right-hand dial knob, set the right ridge former height so that the needle penetrates the desired depth. All further adjustments should be made by using the knurled head crown adjusting screw located in the crown of the presser foot.

To adjust the crown for more penetration of the needle, turn the adjusting screw counterclockwise. For less penetration, turn the screw clockwise.

To increase the spring pressure on the crown, turn the screw in the center of the adjusting screw clockwise, counterclockwise for less pressure. Retighten lock nut.

Pressure is directly applied to the yielding ridge forming disc by adjusting the Allen head screw located in the bottom of same (A, Fig. 10).

Should it become necessary to increase or decrease the height of the discs beyond the limits of the right hand dial range, proceed as follows:

1. Rotate right hand dial, in the required direction, to the end of its travel.
2. Remove screw (A, Fig. 11) and spring (B).
3. Lift the dial knob so that its stop pin disengages from the stationary stop pin in the dial seat, but so that its key slot remains engaged with the key in the dial shaft. Rotate the dial in the required direction until its stop pin passes over the stationary stop pin and the dial reengages.
4. Replace spring and screw.

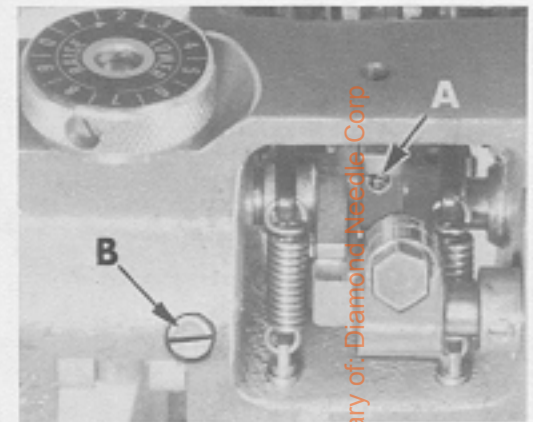

Fig. 10

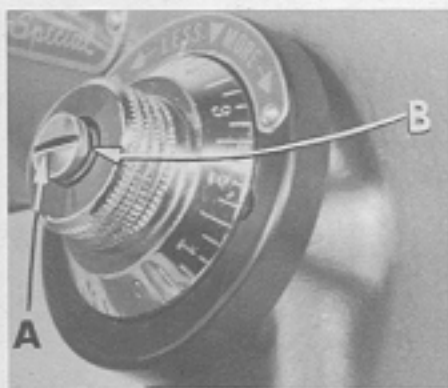

Fig. 11

Refinements of this adjustment, within any range, may be made by adjusting the push rod stop screw (A, Fig. 12).

To increase or decrease the height of the left-hand disc beyond the limits of the left-hand dial range, simply loosen the two locking screws located in the dial and turn the slotted stud located in the center of the dial in the desired direction. Retighten screws.

WORK TABLE TENSION

The position of the ridge forming discs is fixed in the work table. The tension applied to the work table by the large coil spring in the base of the machine controls the tension on the right ridge forming disc.

WORK TABLE TENSION (Continued)

The tension on the left ridge forming disc is independently controlled by a small coil spring located in the under side of the left end of the work table (B, Fig. 10).

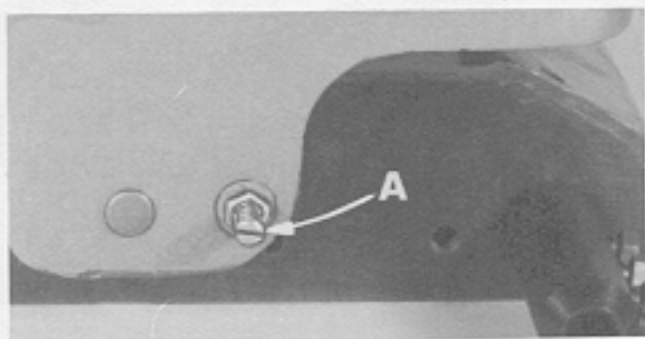

Fig. 12

Tension on both discs can be increased or decreased, depending on the weight of material being sewn, by the following adjustments:

For right hand disc tension, adjust nut (A, Fig. 13). Turning nut clockwise increases tension, counterclockwise acts the reverse. For left hand disc tension, adjust screw (B, Fig. 10). Turning screw clockwise increases tension, counterclockwise acts the reverse.

STARTING TO OPERATE

1. Thread machine in accordance with threading diagram (Fig. 1).
2. Move knee press to right and insert work under feed dog with the folded edge of the material directly over the right ridge forming disc and against the edge guide on the front of the presser foot.
3. Adjust needle penetration. Sew a few stitches and inspect. If the needle does not penetrate the folded edge at the desired depth, turn the right hand dial knob in the required direction. Check penetration at the single ply of fabric and adjust left hand dial knob in the same manner.
4. Adjust crown (G, Fig. 2) and cloth retainer (H), located in the cloth opening (B) of the presser foot, as close to the needle as possible and set relative to the ridge forming discs to firmly hold the work on the discs while the needle is penetrating the material. If the material is carried along with the needle, no loop will form, resulting in skipped stitches and improper needle penetration. Lateral adjustment is secured by loosening screws (J) and moving eccentric adjusting studs (K and L) laterally to desired position. Cloth guide (M) which is fixed to eccentric stud (K) also moves laterally with same.

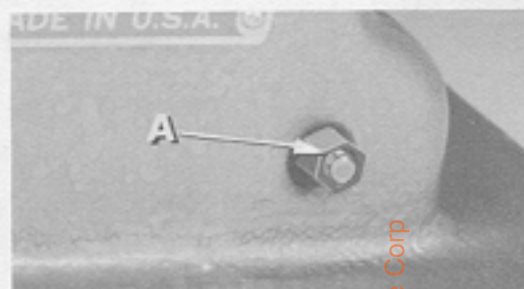

Fig. 13

In-line-of-feed adjustment is made by loosening screws (J) and turning the eccentric adjusting studs (K and L).

Tension on the right hand spring actuated crown is controlled by the knurled adjusting screw (N) and the set screw (P). Refer to adjustment under "Setting Ridge Forming Discs".

Tension on the left hand cloth retainer can be varied by turning the spring adjusting sleeve (Q). Loosen left set screw (J) and set screw (R) while holding adjusting stud (L) in position. Turn spring adjusting sleeve (Q) to secure desired tension and retighten the set screws.